

Technical data sheet



Product features

Chip scuttle + infrared heat lamp

| | | |
|--------------|-----------------|----------|
| Model | SAP Code | 00006956 |
|--------------|-----------------|----------|

- Maximum device temperature [°C]: 90
- Minimum device temperature [°C]: 30
- Material: AISI 430

| | | | |
|------------------------|----------|----------------------------|-----------------------|
| SAP Code | 00006956 | Net Weight [kg] | 8.50 |
| Net Width [mm] | 270 | Power electric [kW] | 0.850 |
| Net Depth [mm] | 330 | Loading | 2x 230 V / 1N - 50 Hz |
| Net Height [mm] | 522 | | |

Technical data sheet



Technical drawing

Chip scuttle + infrared heat lamp

Model

SAP Code

00006956

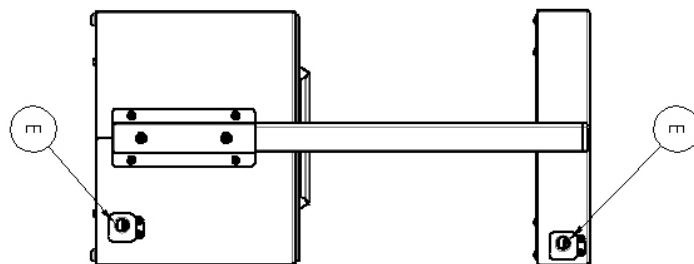
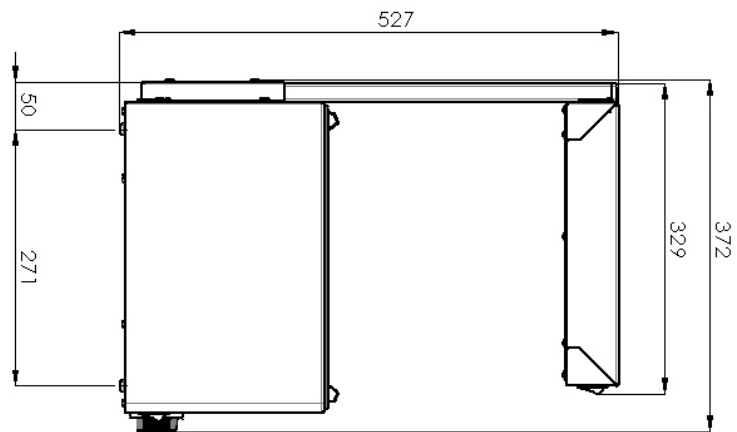
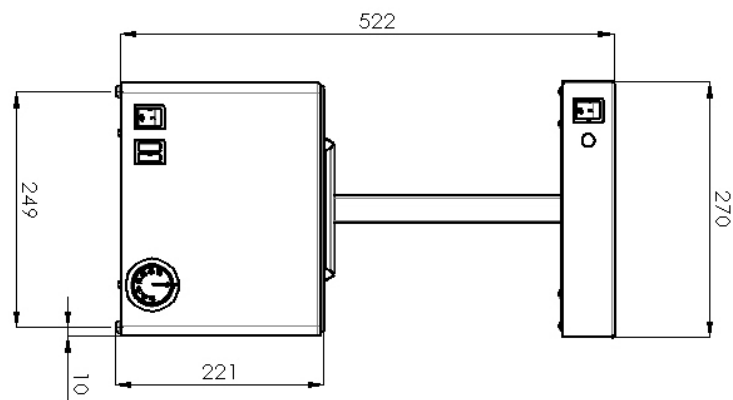

Technical data sheet



Technical parameters

Chip scuttle + infrared heat lamp

Model

SAP Code

00006956

1. SAP Code:

00006956

2. Net Width [mm]:

270

3. Net Depth [mm]:

330

4. Net Height [mm]:

522

5. Net Weight [kg]:

8.50

6. Gross Width [mm]:

345

7. Gross depth [mm]:

350

8. Gross Height [mm]:

530

9. Gross Weight [kg]:

10.00

10. Device type:

Electric unit

11. Construction type of device:

Table top

12. Power electric [kW]:

0.850

13. Loading:

2x 230 V / 1N - 50 Hz

14. Exterior color of the device:

Stainless steel

15. Material:

AISI 430

16. Indicators:

operation and warm-up

17. Maximum device temperature [°C]:

90

18. Minimum device temperature [°C]:

30